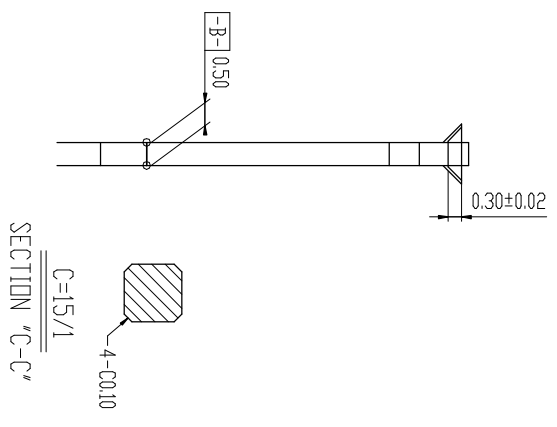
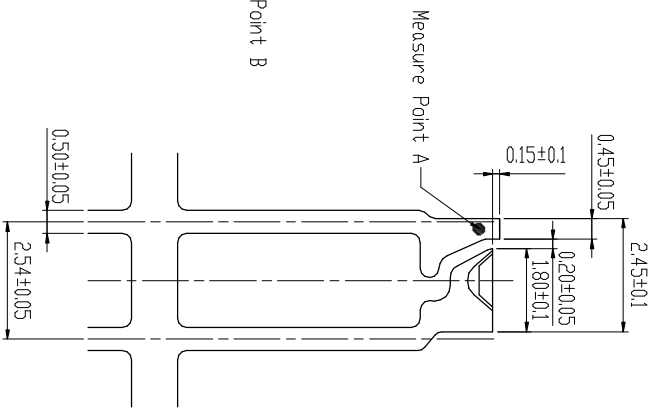
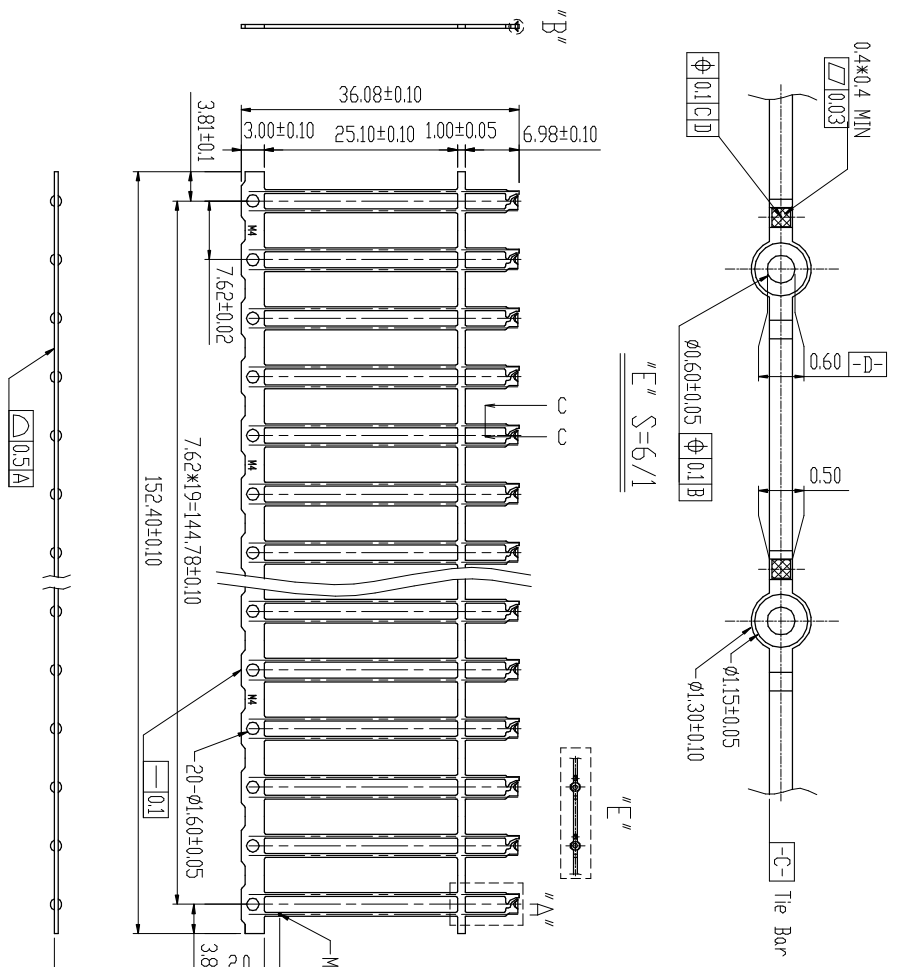

TABLE	UNPLATING/REEL	PLATING	PART NO.	DESCRIPTION		
1	42-33044-001	32-33044-001	32-33044-002	UNDERPLATING   A Point	B Point	PIECE
				CU 10 μ~20μ'	AG 80μ'	AG 50μ'
						20PIN

REVISION			
REV	DESCRIPTION	BY	DATE
A	NEW DRAWING	Ted	11/15/10'



- NOTE:
1. MATERIAL: 0.50±0.025 THICK SPCG-SD.
  2. BURR: 0.05MAX. UNLESS OTHERWISE SPECIFIED.
  3. RADIUS: 0.30 MAX. ON ALL SHARP CORNERS UNLESS OTHERWISE SPECIFIED.
  4. BDW: NOT TO EXCEED 0.50 IN A 20 FRAME STRIP.
  5. CROSS BDW: NOT TO EXCEED 0.20 TO 36.08 WIDTHH.
  6. TWIST: 0.50 MAX. IN A FRAME STRIP.
  7. CAMBER: LESS THAN 0.10 WHEN MEASURE OVER 20 POSITIONS.
  8. TWISTING ANGLE: ±2° MAX. OF THE BDWL.
  9. TOLERANCE: IS ±0.10 UNLESS OTHERWISE SPECIFIED.

	ANGLES 0°±20'				
	MM	DR	Ted	DATE	MAT'L
0.0±0.13	CHK		11/15/10'	SEE NOTE 1	
0.00±0.05	ENGR			FINISH	
0.000±0.03	APPD			SEE NOTE 2	
				DWG. NO.	
				M0344	

CHALIN PRECISION INDUSTRIAL CO., LTD.			
DWG TYPE	TITLE	REV	
C	2004M4	A	
SCALE	SIZE	PART. NO.	
1:1	A4	32-33044-002	
		SHT 1 OF 1	