

UNPLATING/REFL	PLATING	PART NO.	DESCRIPTION		PIECE
B86600000A	B8660015A	B8660015A	UNDERPLATING	A Point B Point	15PIN

REVISION			
REV	DESCRIPTION	BY	DATE
A	NEW DRAWING	J.S.SHEU	02/13/09
B	ECN 1007-005	JOE	07/06/10
C	ECN 011-001	Ted	11/04/10

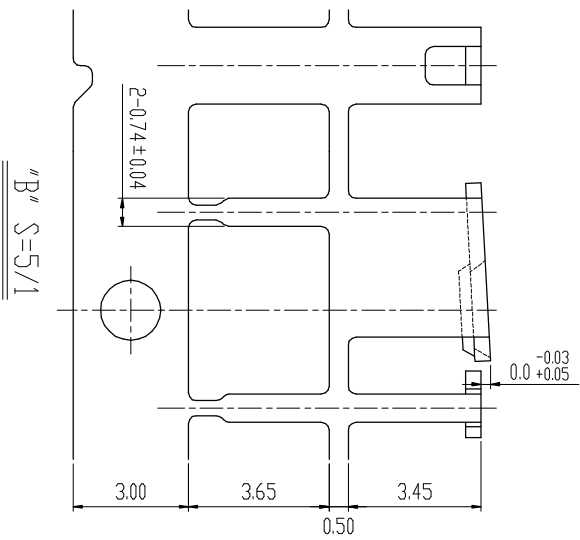
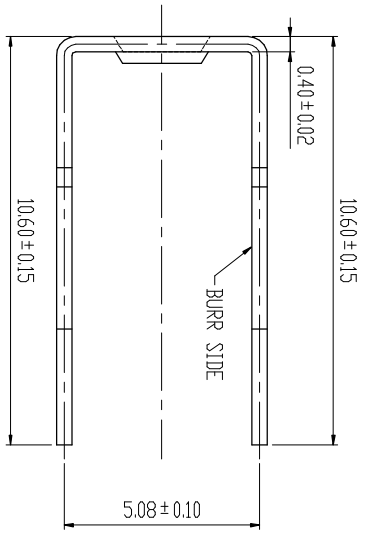
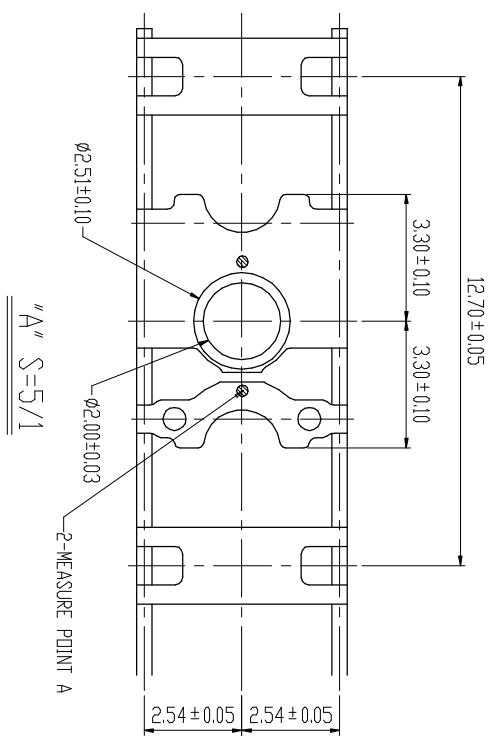
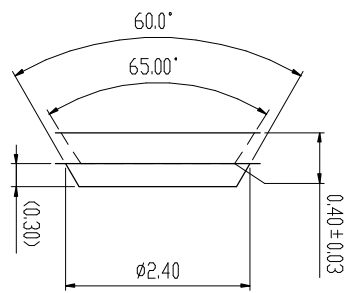
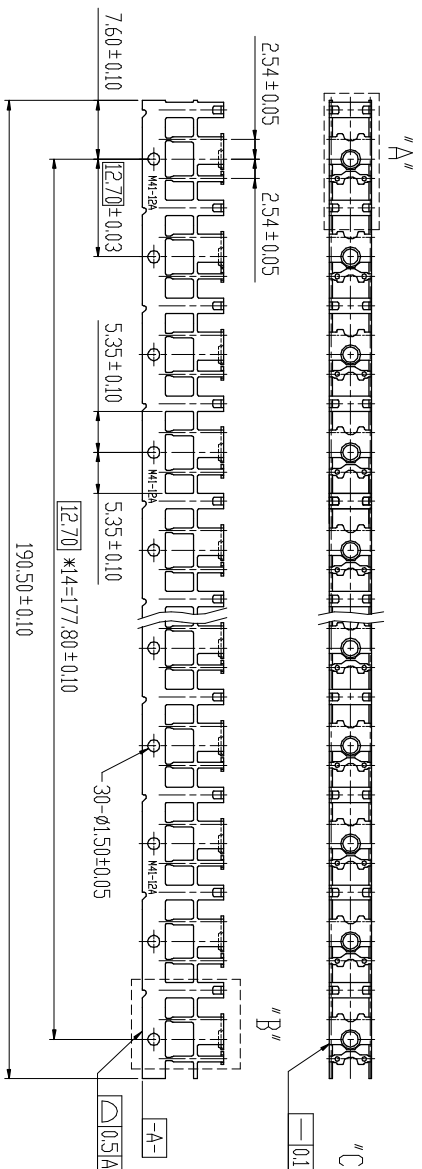

- NOTE:
1. MATERIAL: 0.40±0.02 THICK COPPER ALLOY-194 1/2H.
 2. PLATING OF NONE MEASURING POINT FOR TABLE : AG 30u" MIN.
 3. RADIUS: 0.30 MAX. ON ALL SHARP CORNERS UNLESS OTHERWISE SPECIFIED.
 4. BURR: 0.03 MAX. UNLESS OTHERWISE SPECIFIED.
 5. CAN NOT BE DISCOLDR AFTER BY 170° BAKING FOR 15 HOURS.

ANGLES 0°±20°		M/M	DR	DATE	MAT'L
	0.0±0.13	CHK	Ted	11/04/10'	SEE NOTE 1
	0.00±0.05	ENGR	Ted	11/04/10'	FINISH SEE PART NO. TABLE
	0.000±0.03	APPD			DWG. NO. M0346

CHALIN PRECISION INDUSTRIAL CO., LTD.			
DWG TYPE	TITLE	SCALE	SIZE
C	2041-M41-12AU	1:1	A4
REV	PART NO.	E03046-B866XU15A	
C		SHT 1 OF 2	