

REVISION			
REV	DESCRIPTION	BY	DATE
A	NEW DRAWING	J.S.SHEU	05/12/05'
B	MODIFY P/N	J.S.SHEU	01/02/07'

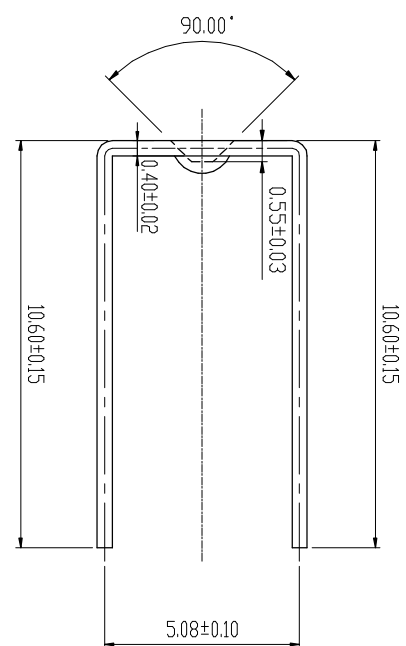
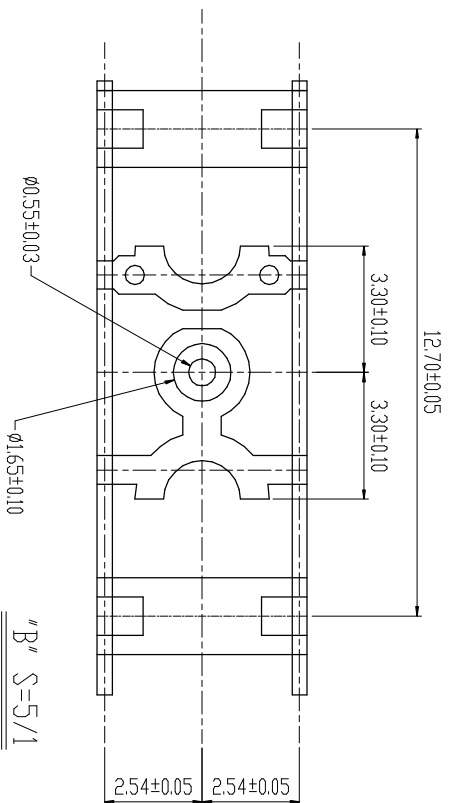
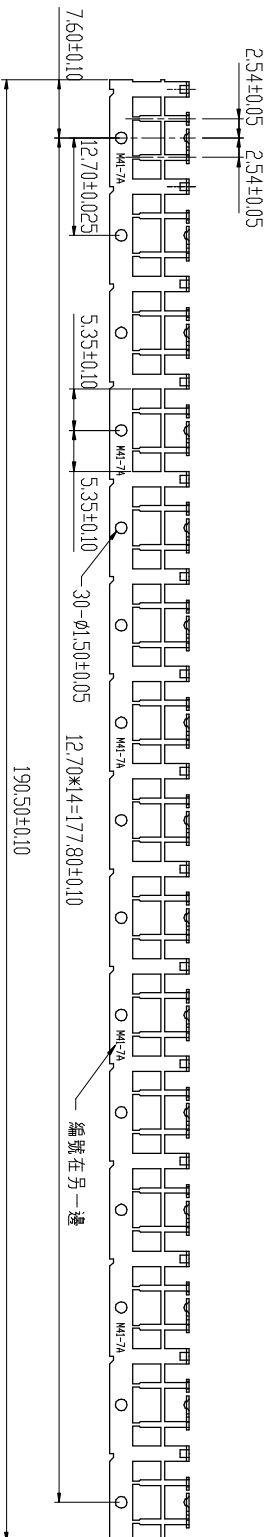

NOTES:

1. MATERIAL: 0.4±0.02 THICK ALLOY-194
2. BURR: 0.05MAX. UNLESS OTHERWISE SPECIFIED.
3. RADIUS: 0.3MAX ON ALL SHARP CORNERS UNLESS OTHERWISE SPECIFIED.
4. BOW: NOT TO EXCEED 0.5 IN A 15 FRAME STRIP.
5. GROSS BOW: NOT TO EXCEED 0.15 TO 25.4 WIDTH.
6. TWIST: 0.5MAX. IN A 15 FRAME STRIP.
7. CAMBER: LESS THAN 01 WHEN MEASURED OVER 15 POSITIONS.
8. TWISTING ANGLE: ±2°MAX. OF THE BOWL.
9. TOLERANCE: ±01 UNLESS OTHERWISE SPECIFIED.

A766000A	AG80U" REEL
A7666U15A	AG80U" 15PIN

ANGLES 0°±2'0"		DR		DATE		MAT'L	
MM		J.S.SHEU		01/02/07'		SEE NOTE 1	
0.0±0.13	CHK	J.S.SHEU		01/02/07'		FINISH SEE NOTE 2	
0.00±0.05	ENGR					DWG. NO. M0346	
0.000±0.03	APPD						

TITLE				SCALE		SIZE		PART. NO.		REV	
CHAIN PRECISION INDUSTRIAL CO., LTD.				1:1		A4		E0346-A766U15A		B	
2041-M41-7AU										SHT 1 OF 1	