

UNPLATING REEL	PLATING	PART NO.	DESCRIPTION		PIECE
A86600000A	A8660015A	A8660015A	UNDERPLATING	A Point B Point	15PIN
			CU 20μ~30μ	AG 80μ	

REV	DESCRIPTION	BY	DATE
A	NEW DRAWING	J.S.SHEU	02/13/09
B	EN 1007-005	JOE	07/06/10
C	EON1011-001	Ted	11/04/10

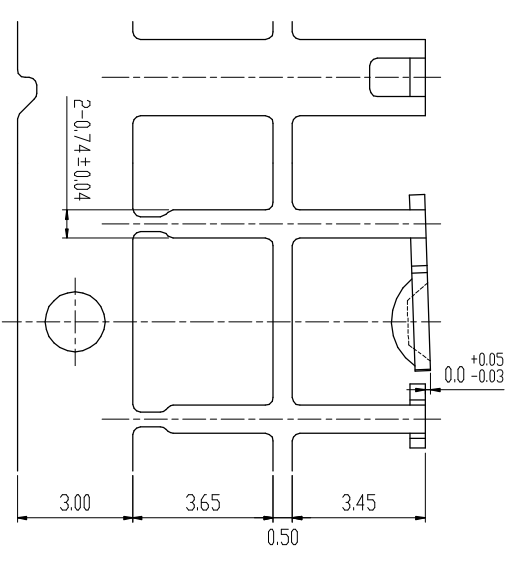
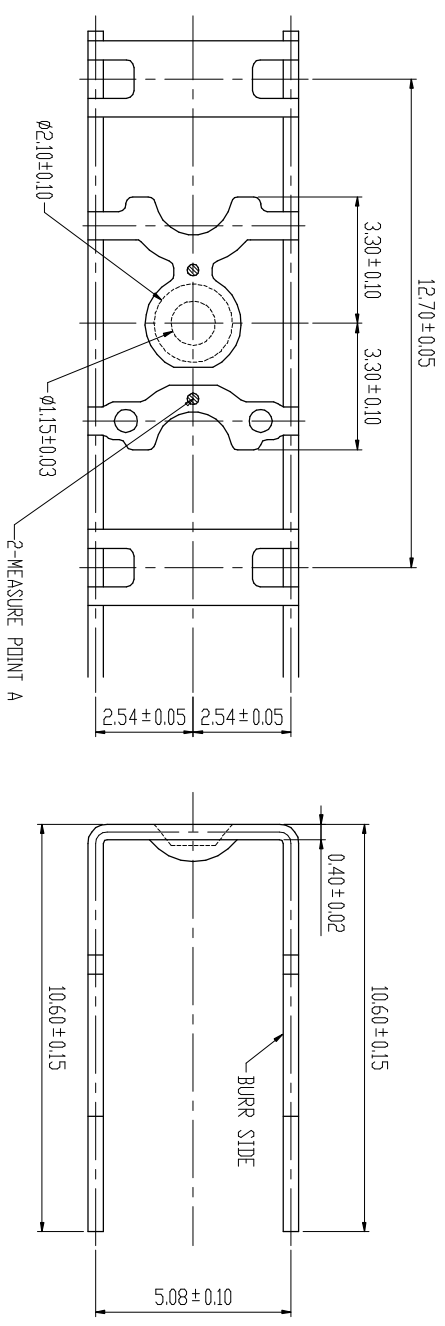
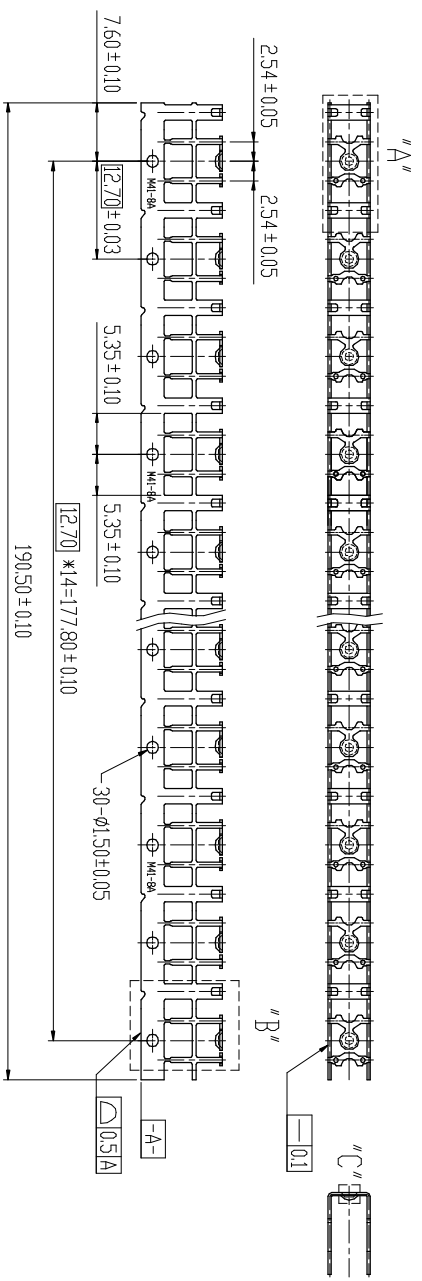

- NOTE:
1. MATERIAL: 0.40±0.02 THICK COPPER ALLOY-194 1/2H
 2. PLATING DF NONE MEASURING POINT FOR TABLE : AG 30μ MIN.
 3. RADIUS: 0.30 MAX. ON ALL SHARP CORNERS UNLESS OTHERWISE SPECIFIED.
 4. BURR: 0.03 MAX. UNLESS OTHERWISE SPECIFIED.
 5. CAN NOT BE DISCOLD AFTER BY 170° BAKING FOR 1.5 HOURS.

DR	DATE	MAT'L	FINISH	DR	DATE	MAT'L
Ted	11/04/10	SEE NOTE 1	SEE PART NO. TABLE	Ted	11/04/10	SEE NOTE 1
CHK				ENGR		
0.0±0.13				0.00±0.05		
0.000±0.03				APPD		

CHALIN PRECISION INDUSTRIAL CO., LTD.		SCALE		SIZE		PART NO.	
DWG TYPE		1:1		A4		E03046-A866XU15A	
TITLE		C		A4		E03046-A866XU15A	
2041-M41-8AU		REV		C		SHT 1 OF 2	

